

# Analog Signal Generator

## Models AP5031A and AP5032A

Single- and Multi-Channel High Performance Generators  
1 kHz to 12.75, 20, 40, and 51 GHz



# About the AP503xA Generators

The AP503xA Series of Analog Signal Generators are a series of phase-coherent, single or multi-channel, ultra-fast switching and ultra-low phase noise signal generators with a frequency range from 1 kHz to 12.75, 20, 40, and 51 GHz. They are ideally suited for a wide range of applications, where good signal quality, accurate and wide output power ranges, and very stable phase coherence among all channels are required. Outstanding phase noise is combined with good spurious, harmonic rejection and ultra-fast switching of < 10 us.

A high-stability OCXO reference provides excellent frequency accuracy and stability. The generator accepts a wide range of external references; common 10 and 100 MHz and variable references from 1-250 MHz for applications requiring system-specific reference frequencies. Moreover, the generators feature 3 GHz input and output clock ports that enable excellent phase synchronization among the output channels of multiple instruments.

The single-channel AP5031A model comes in a desktop enclosure, while the multi-channel AP5032A model comes in a 19-inch, 2U height rack-mountable chassis. Instrument control is via touchscreen (AP5031A) or by a PC-based application or WebUI (AP5031A and AP5032A). Various communication interfaces like USB, LAN, or GPIB are available to support test automation using SCPI 1999 compatible commands from a user API or programming examples from commercially available tools.

## Definitions and Conditions

Specification (spec):

The specifications (called out as spec) in the following pages describe the warranted performance of a calibrated instrument for  $23 \pm 5$  °C after a 30-minute warm-up period (unless otherwise stated). Specifications include guard-bands to account for the expected statistical performance distribution, measurement uncertainties, and changes in performance due to environmental conditions.

Nominal (nom):

Values indicate the expected mean or average performance, or a parameter whose performance is by design, such as the 50-ohm connector. This data is not warranted and is measured at room temperature (approximately 25 °C).

# Table of Contents

About the AP503xA Generators.....	2
Definitions and Conditions .....	2
Table of Contents.....	3
Parameters & Specifications.....	4
Frequency .....	4
Phase Noise.....	5
Jitter Specifications .....	7
Spectral Purity.....	7
Channel to Channel Performance.....	8
Output Power .....	9
Modulation Capabilities .....	12
Sweeping Capability.....	15
Trigger Input.....	15
Multi-Purpose Output .....	16
Connectors .....	17
Mechanical Specifications.....	20
General Characteristics.....	21

# Parameters & Specifications

## Frequency

Parameter	Nominal (unless otherwise indicated)	Note
Channels	1 1 to 4	AP5031A AP5032A
Frequency ranges	1 kHz to 12.75 GHz 1 kHz to 20 GHz 1 kHz to 40 GHz 1 kHz to 51 GHz	Option 512 Option 520 Option 540 Option 551
Resolution	0.001 Hz	
Phase adjustment range	0 to 360°	Individually adjustable per channel
Phase resolution	0.1 deg	
Thermal drift	0.015 dB/°C	
Internal reference frequency	100 MHz 10 MHz	Option LN1 Option LN2
Temperature stability 0 to 50 °C	±100 ppb ±20 ppb	Option LN1 Option LN2
Frequency accuracy	1000 ppb (spec) 20 ppb (spec)	Option LN1 Option LN2
Aging per day	5 ppb < 0.5 ppb	after 30 days of operation Option LN1 Option LN2
Warm-up time	5 min	
Internal reference output	10, 100 MHz	Selectable
High frequency clock output	3 GHz	
Output power level range	+10 to +13 dBm +5 to + 10 dBm	3 GHz 10/100 MHz
External reference frequency	10, 100 MHz 1 MHz to 250 MHz 3 GHz	Options LN1 or LN2 Option 1ER, Option LN2 disabled CLK IN, bypass internal reference Accepts sine wave and square wave
Reference input level range	-10 to +10 dBm +10 to +13 dBm	1-250 MHz 3 GHz CLK IN
Lock Range	±0.3 ppm ±1.5 ppm ±100 ppm	LN2 or LN2 with 1ER LN1 or LN1 with 1ER CLK IN, bypass internal reference
Reference ports impedances	50 Ohm	

# Phase Noise

## Absolute SSB Phase Noise with LN1 Option, dBc/Hz

Specified values in plain text, Nominal values in parentheses. CW, level = +10 dBm

Carrier frequency	10 Hz	100 Hz	1 kHz	Offset 10 kHz	100 kHz	1 MHz	10 MHz
100 MHz	-100 (-105)	-130 (-135)	-144	-150	-156	-156	-156
1 GHz	-80 (-85)	-110 (-115)	-140 (-142)	-147 (-150)	-150 (-152)	-150 (-153)	-150 (-153)
4 GHz	-68 (-73)	-98 (-103)	-130 (-132)	-137 (-139)	-144(-146)	-145 (-148)	-145 (-148)
6 GHz	-64 (-69)	-95 (-100)	-127 (-130)	-136 (-139)	-141 (-143)	-147 (-149)	-147 (-150)
10 GHz	-60 (-65)	-90 (-95)	-123 (-125)	-133 (-135)	-138 (-140)	-144 (-145)	-144 (-145)
20 GHz	-54 (-59)	-84 (-89)	-117 (-119)	-127 (-129)	-133 (-134)	-138 (-139)	-138 (-139)
40 GHz	-48 (-53)	-78 (-83)	-111 (-113)	-121 (-123)	-127 (-128)	-132 (-133)	-132 (-133)
50 GHz	-46 (-51)	-76 (-81)	-109 (-111)	-119 (-121)	-125 (-126)	-130 (-131)	-130 (-131)

## Absolute SSB Phase Noise with LN2 Option, dBc/Hz

Specified values in plain text, Nominal values in parentheses. CW, level = +10 dBm

Carrier frequency	10 Hz	100 Hz	1 kHz	Offset 10 kHz	100 kHz	1 MHz	10 MHz
100 MHz	-120 (-123)	-130 (-135)	-144	-150	-156	-156	-156
1 GHz	-100 (-103)	-110 (-115)	-140 (-142)	-147 (-150)	-150 (-152)	-150 (-153)	-150 (-153)
4 GHz	-88 (-91)	-98 (-103)	-130 (-132)	-137 (-139)	-144(-146)	-145 (-148)	-145 (-148)
6 GHz	-84 (-87)	-95 (-100)	-127 (-130)	-136 (-139)	-141 (-143)	-147 (-149)	-147 (-150)
10 GHz	-80 (-83)	-90 (-95)	-123 (-125)	-133 (-135)	-138 (-140)	-144 (-145)	-144 (-145)
20 GHz	-74 (-77)	-84 (-89)	-117 (-119)	-127 (-129)	-133 (-134)	-138 (-139)	-138 (-139)
40 GHz	-68 (-71)	-78 (-83)	-111 (-113)	-121 (-123)	-127 (-128)	-132 (-133)	-132 (-133)
50 GHz	-66 (-69)	-76 (-81)	-109 (-111)	-119 (-121)	-125 (-126)	-130 (-131)	-130 (-131)

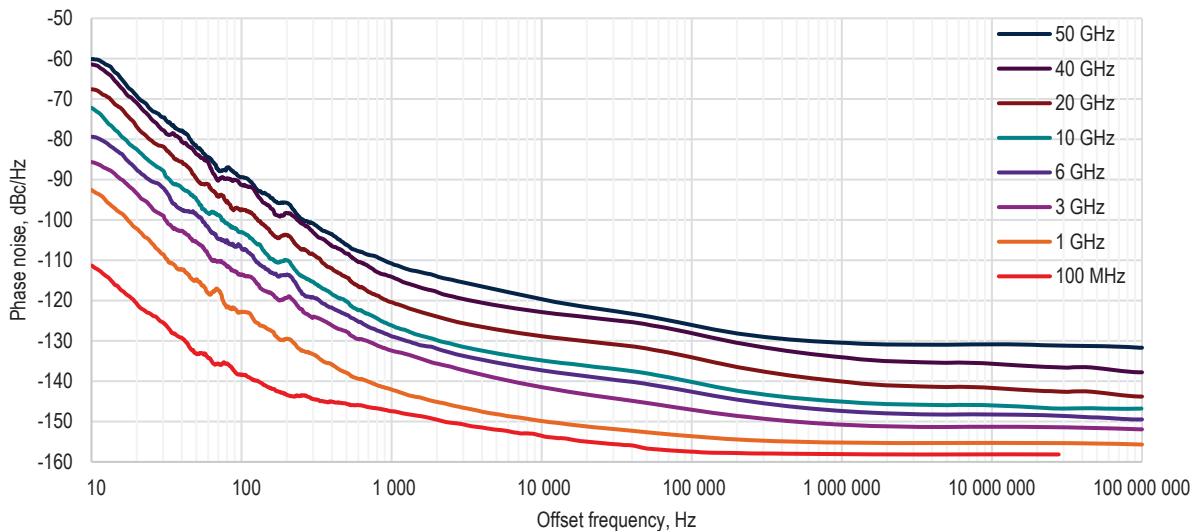

**Figure 1.** Phase noise at different frequencies. Option LN1, +10 dBm

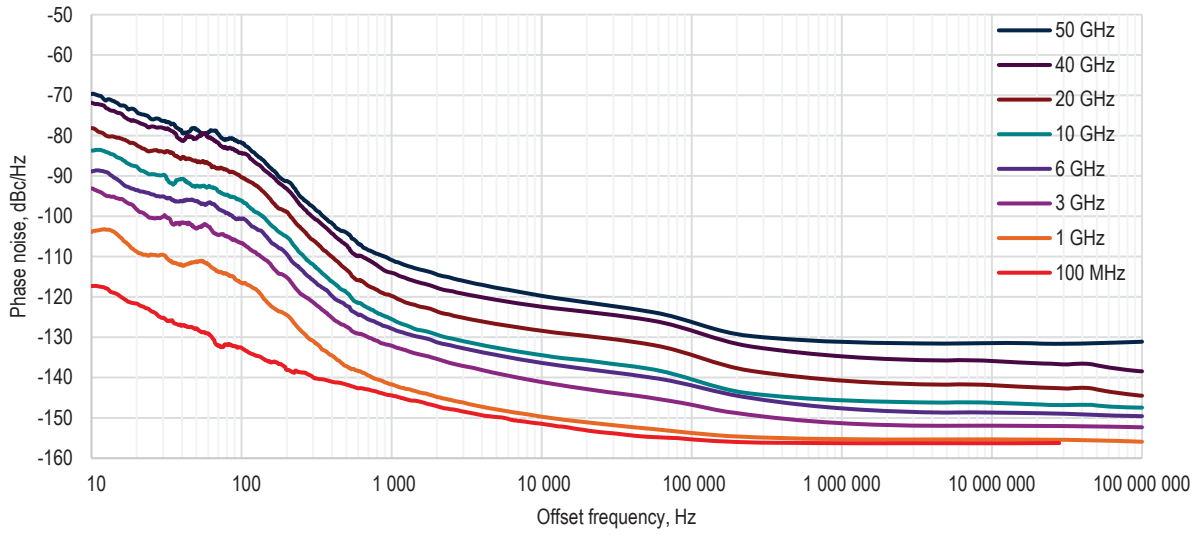

**Figure 2.** Phase noise at different frequencies. Option LN2, +10 dBm

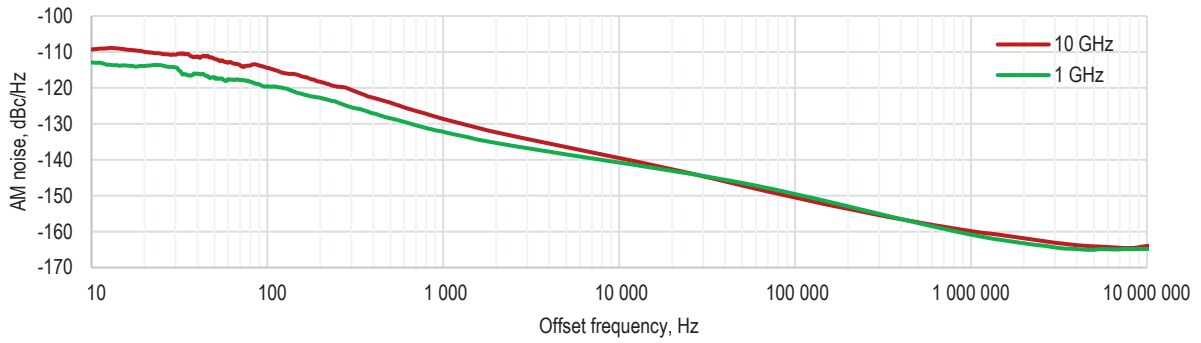

**Figure 3.** Amplitude noise at different frequencies. Power level +10 dBm

## Jitter Specifications

Carrier frequency	Nominal	Note
155 MHz	30 fs	BW 100 Hz to 1.5 MHz, 10 dBm (for option LN1 and LN2)
622 MHz	15 fs	BW 1 kHz to 5 MHz, 10 dBm (for option LN1 and LN2)
1 GHz	15 fs	BW 10 Hz to 10 MHz, 10 dBm (for option LN2 only)
2.488 GHz	9.5 fs	BW 5 kHz to 20 MHz, 10 dBm (for option LN1 and LN2)
9.952 GHz	10 fs	BW 10 kHz to 80 MHz, 10 dBm (for option LN1 and LN2)
39.812 GHz	18 fs	BW 40 kHz to 320 MHz, 10 dBm (for option LN1 and LN2)

## Spectral Purity

Parameter	Nominal	Spec	Note
<b>Harmonics</b>			At +10 dBm output power
1 kHz to <350 MHz	-35 dBc	-30 dBc	(50 MHz to 350 MHz; at -10 dBm output power, nominal harmonics are -50 dBc)
350 MHz to <8 GHz	-60 dBc	-50 dBc	
8 GHz to <22 GHz	-65 dBc	-50 dBc	
22 GHz to <30 GHz	-25 dBc	-20 dBc	
22 GHz to <30 GHz	-25 dBc	-50 dBc	Option 1EH
30 GHz to <51 GHz	-60 dBc		
<b>Sub-harmonics</b>			At +10 dBm output power
1 kHz to <350 MHz	-80 dBc		
350 MHz to <12.84 GHz	-75 dBc	-55 dBc	Incl. high-order subharmonics
12.84 GHz to <51 GHz	-70 dBc	-50 dBc	
<b>Non-harmonic spurious</b>			At +10 dBm, 10 kHz to 0.35 GHz offset from carrier
1 kHz to <350 MHz	-70 dBc	-60 dBc	
350 MHz to <6.42 GHz	-85 dBc	-75 dBc	
6.42 GHz to <12.84 GHz	-80 dBc	-70 dBc	
12.84 GHz to <22 GHz	-75 dBc	-65 dBc	
22 GHz to <51 GHz	-70 dBc	-55 dBc	

Note: Performance data are nominal for harmonics beyond specified frequency range.

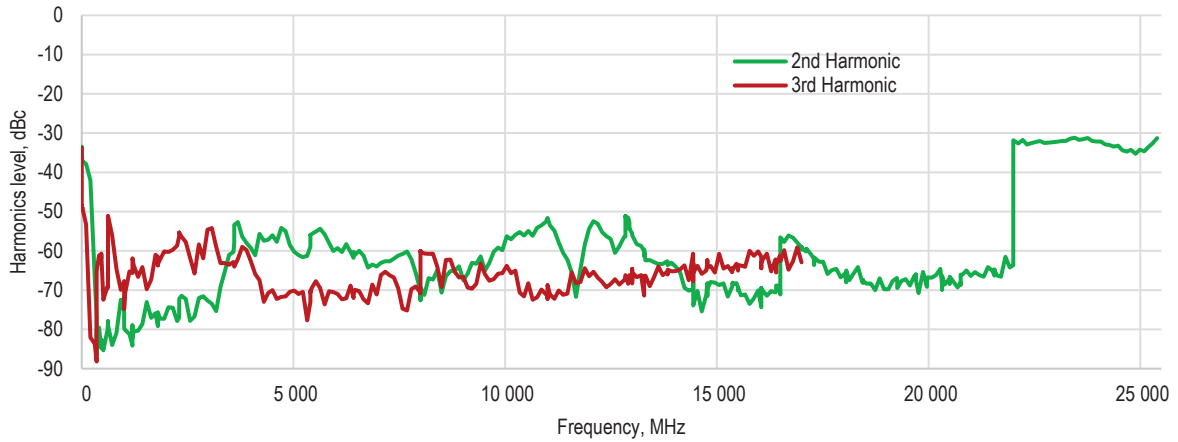

Figure 4. Harmonics at 10 dBm

## Channel to Channel Performance

Parameter	Nominal	Note
<b>Relative Phase Stability</b>		See figure 5
Between channels	2 deg p-p	Measured 0.36 deg RMS over 10 hours
Between synchronized devices	2 deg p-p	Measured 0.36 deg RMS over 10 hours
<b>Channel-to-channel isolation</b>	110 dB	9 kHz to 50 GHz, 10 dBm, outputs are terminated with 50 Ohm

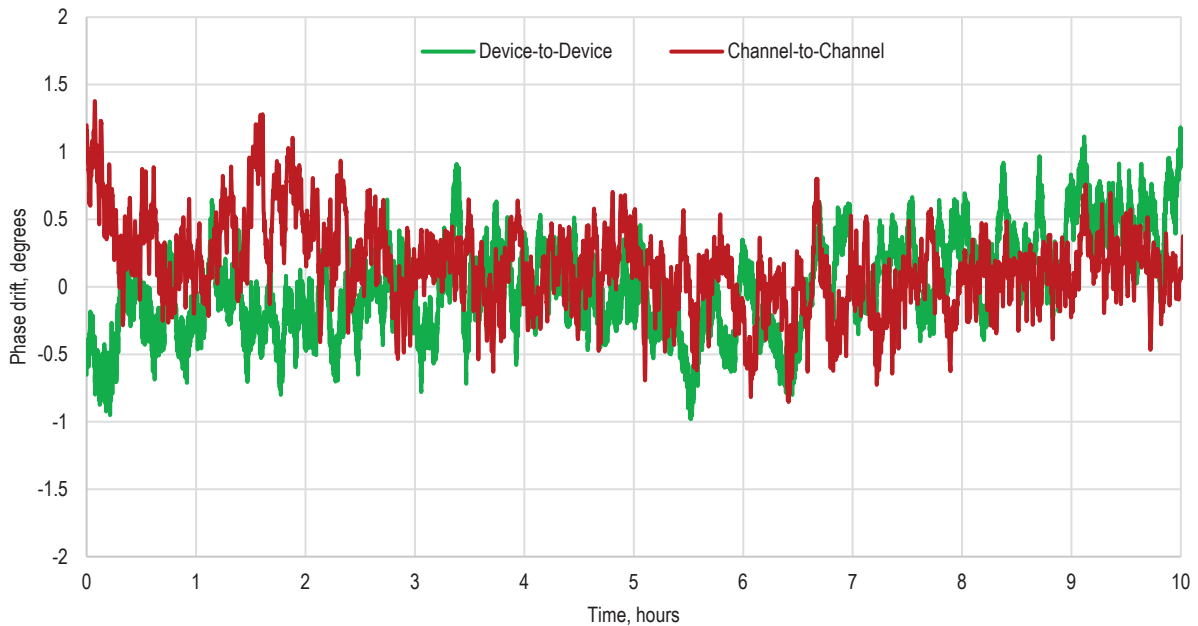
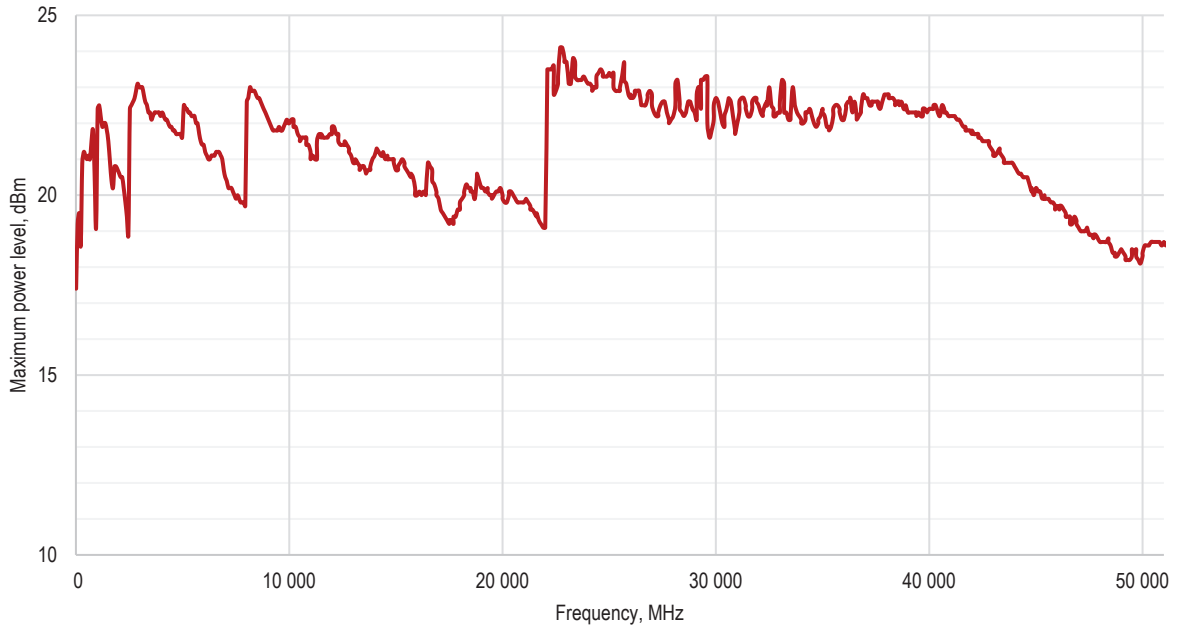

Figure 5. Relative phase drift for 50 GHz, 0 dBm output in temperature-controlled environment over 10 hours

# Output Power

Parameter	Min	Max (spec)	Note
<b>Output power level</b>			Options 512, 520, 540, 551
1 kHz to <1 MHz	-20 dBm	+10 dBm	
1 MHz to <10 MHz	-20 dBm	+12 dBm	
10 MHz to <2.5 GHz	-20 dBm	+18 dBm	
2.5 GHz to <40 GHz	-20 dBm	+18 dBm	
40 GHz to <51 GHz	-20 dBm	+15 dBm	
<b>Output power level</b>			Options 512, 520, 540 and 1E1
1 kHz to <1 MHz	-120 dBm	+10 dBm	
1 MHz to <10 MHz	-120 dBm	+12 dBm	
10 MHz to <2.5 GHz	-120 dBm	+16 dBm	
2.5 GHz to <40 GHz	-120 dBm	+16 dBm	
<b>Output power level</b>			Options 512, 520, 540, 1E1 and 1EH
1 kHz to <1 MHz	-120 dBm	+10 dBm	
1 MHz to 5 GHz	-120 dBm	+16.5 dBm	
>5 GHz to 20 GHz	-120 dBm	+17 dBm	
>20 GHz to 30 GHz	-120 dBm	+16 dBm	
>30 GHz to 40 GHz	-120 dBm	+15 dBm	
<b>Output power level</b>			Options 551 and 2E1
1 kHz to <1 MHz	-110 dBm	+10 dBm	
1 MHz to <10 MHz	-110 dBm	+12 dBm	
10 MHz to <2.5 GHz	-110 dBm	+16 dBm	
2.5 GHz to <40 GHz	-110 dBm	+16 dBm	
40 GHz to <51 GHz	-110 dBm	+12 dBm	
<b>Power resolution</b>	0.01 dB		
<b>Reverse power protection</b>	<b>Nominal</b>		
DC Voltage	0 V		
RF Power	26 dBm		
<b>Output impedance</b>	50 Ohms		
<b>VSWR <math>\geq</math>-20 dBm</b>	1.3 (nominal) 1.3 (nominal) 1.4 (nominal)	< 15 GHz 15 to <48 GHz 48 to 51 GHz	
<b>VSWR &lt;-20 dBm</b>	1.1 (nominal) 1.5 (nominal) 1.6 (nominal)	< 15 GHz 15 to <48 GHz 48 to 51 GHz	



**Figure 6.** Measured maximum output power, 10 MHz to 51 GHz

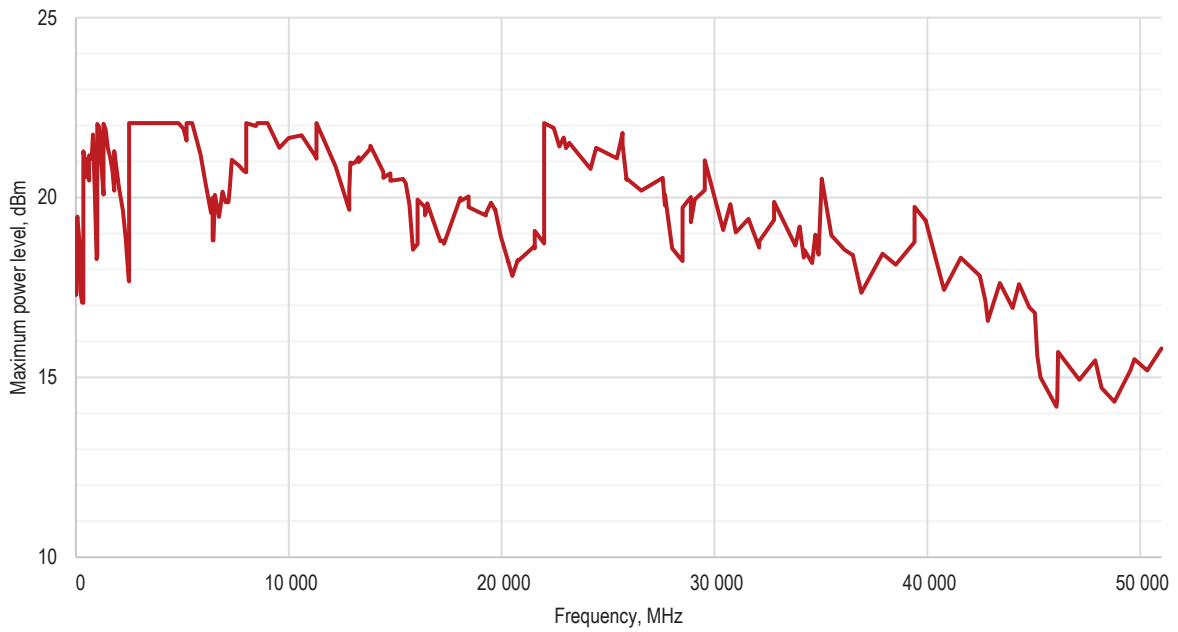

**Figure 7.** Measured maximum output power, 10 MHz to 51 GHz (Option 2E1)

## Power Level Accuracy

Absolute power level accuracy. Specified values in plain text, Nominal values in parentheses

Frequency Range	-110 to <-50 dBm Option 1E1 or 2E1	-50 to <-20 dBm Option 1E1 or 2E1	-20 to <+15 dBm	+15 dBm to max power
1 kHz to <10 MHz	(±2.2 dB)	±1 dB (±0.5 dB)	±0.8 dB (±0.15 dB)	±1.5 dB (±0.3 dB)
10 MHz to <1 GHz	(±2.2 dB)	±1 dB (±0.5 dB)	±0.8 dB (±0.15 dB)	±1.5 dB (±0.3 dB)
1 to <22 GHz	(±2.2 dB)	±1 dB (±0.6 dB)	±0.5 dB (±0.2 dB)	±1.5 dB (±0.3 dB)
22 to <40 GHz	(±2.5 dB)	±2 dB (±1.2 dB)	±1.2 dB (±0.4 dB)	±1.5 dB (±0.4 dB)
40 to 51 GHz	(±2.5 dB)	(±2 dB)	±1.3 dB (±0.4 dB)	±1.5 dB (±0.5 dB)

## Relative Power Level Linearity

Step of 0.1 dB. Values listed are nominal.

Frequency Range	-110 to <-90 dBm Option 1E1 or 2E1	-90 to <-20 dBm Option 1E1 or 2E1	-20 to <+15 dBm	+15 dBm to Max Power
1 kHz to <10 MHz	(< 0.1 dB)	(< 0.1 dB)	(< 0.1 dB)	(< 0.1 dB)
10 MHz to <1 GHz	(< 0.1 dB)	(< 0.1 dB)	(< 0.1 dB)	(< 0.1 dB)
1 GHz to 51 GHz	(< 0.1 dB)	(< 0.1 dB)	(< 0.1 dB)	(< 0.1 dB)

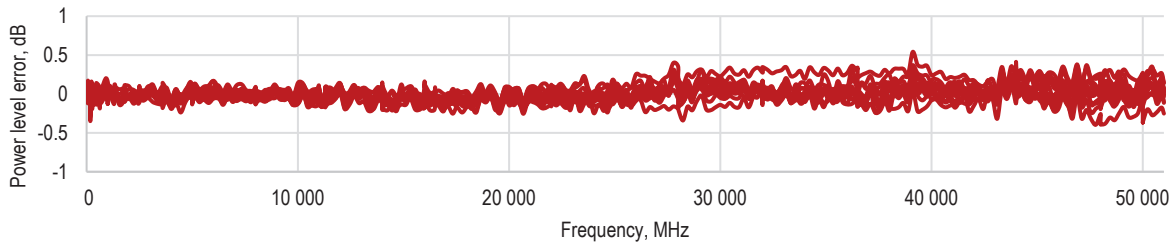

Figure 8. Absolute power level accuracy between -20 and +15 dBm over frequency (Option 551)

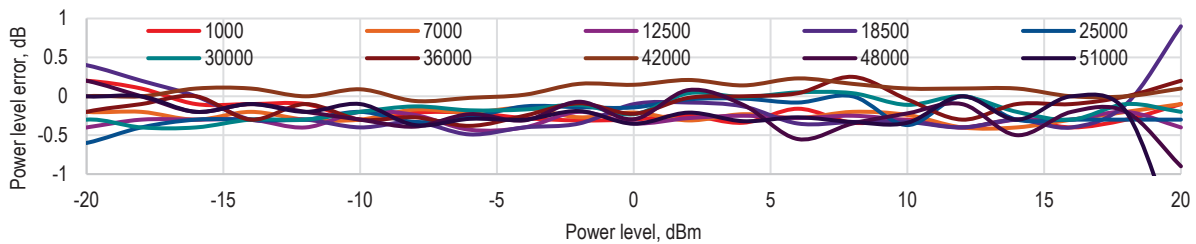

Figure 9. Absolute power level accuracy at different frequencies (Option 551)

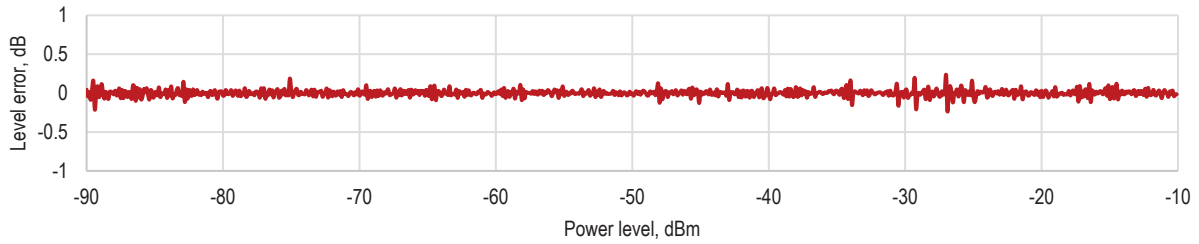
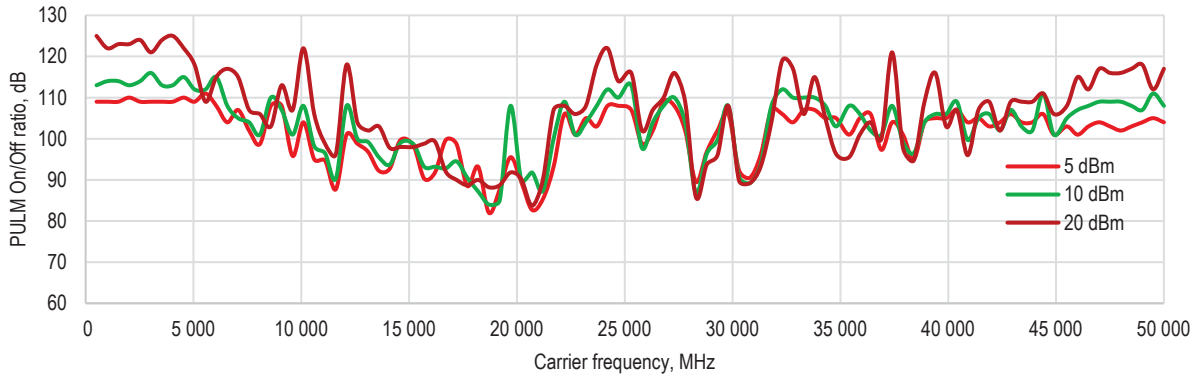

Figure 10. Relative power level accuracy at 20 GHz (Options 520 and 1E1)

## Modulation Capabilities

Parameter	Nominal (unless otherwise indicated)	Note
<b>Pulse modulation</b>		Option PMR, PME, ALC OFF
Modulation source	Internal/External	
External input amplitude	TTL	
Pulse rise/fall time	5 ns (spec)	
On/off ratio	80 dB	Power $\geq$ +10 dBm
Pulse overshoot	10%	
Pulse delay	20 ns	
Pulse polarity	Normal, inverse	selectable
<b>Internal pulse generator</b>		
Repetition frequency (PRF)	0.1 Hz to 50 MHz	$= 1/T$ (pulse period 20 ns to 10,000 s)
Duty cycle	1 % to 99 % in 1% steps	within specified minimum pulse width
Pulse pattern modulation & staggered PRF	using internal pattern generator	
Pulse width	10 ns to 20 s	Option PMR
Programmable pattern length	2 to 65536	
Duty cycle	0.05% to 99.95%	
Pulse width resolution	5 ns	
Pulse period (T) accuracy	$5 \cdot 10^{-6} \cdot T + 3\text{ns}$	
Pulse width accuracy	$5 \cdot 10^{-6} \cdot T + 5\text{ns}$	
Pulse jitter	2 ns	
Polarity	selectable	



**Figure 11.** Pulse on/off ratio

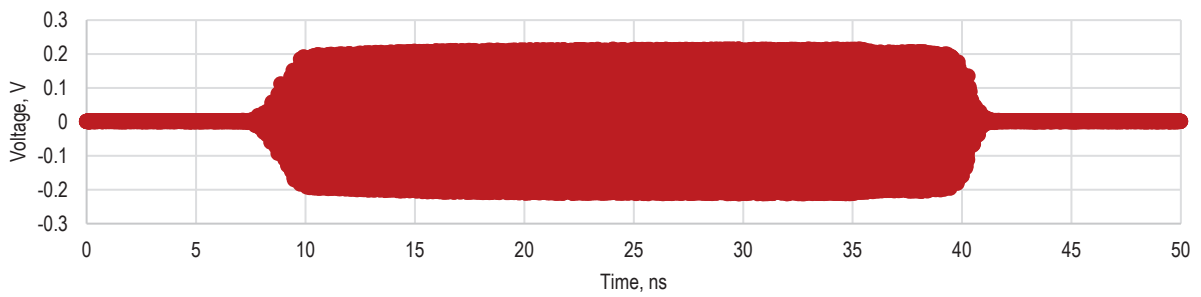

**Figure 12.** 10 GHz pulse-modulated

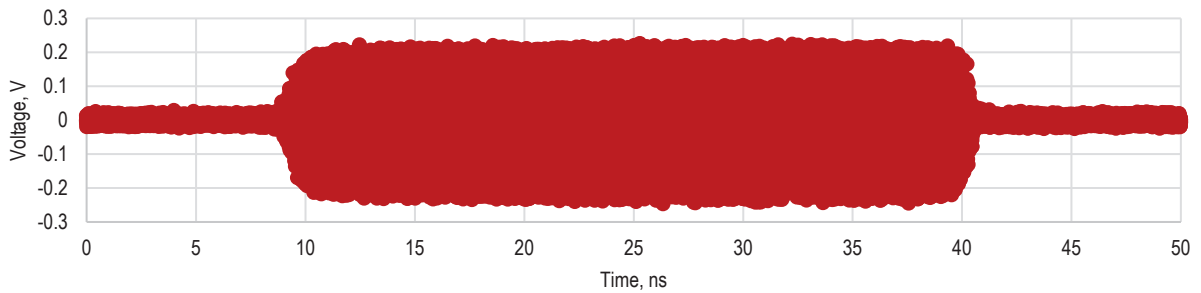

**Figure 13.** 50 GHz pulse-modulated

## Modulation Capabilities (continued)

Parameter	Nominal	Note
<b>Amplitude modulation</b>		Option UNT
Modulation source	Internal	
Modulation depth	0 to 100%	
Depth accuracy	0.05·DEPTH+2% (spec)	1 kHz rate, 30% depth >10 MHz for -10 to +10 dBm
	0.05·DEPTH+2% (spec)	1 kHz rate, 30% depth >10 MHz for -10 to +10 dBm and ≤ -20 dBm with options xE1
Depth resolution	1%	
Distortion (THD)	3% (spec)	1 kHz rate, 30% depth
Modulation rate	0.1 Hz to 30 kHz	
Modulation waveforms	Sine	
<b>Frequency modulation</b>		Option UNT
Modulation source	Internal	
Frequency deviation (peak)	N·5 MHz	Or 10% of carrier whichever is lower. For N values see below
Deviation accuracy	0.01·DEVIATION+2 Hz	
Distortion (THD)	3% (spec)	1 kHz rate, 10 kHz deviation
Modulation rate	0.1 Hz to 30 kHz	
Modulation waveforms	Sine	
<b>Phase modulation</b>		Option UNT
Modulation Source	Internal	
Phase deviation (peak)	N·100 rad	For N values see below
Deviation accuracy	0.01·DEVIATION+10 <sup>-3</sup> rads	
Modulation rate	0.1 Hz to 30 kHz	
Distortion (THD)	3% (spec)	1 kHz rate, 10·N rad deviation
Modulation waveforms	Sine	

Note:

N=1 for frequencies 1 kHz to <350 MHz  
 N=1/32 for frequencies 350 to <401.25 MHz  
 N=1/16 for frequencies 401.25 to <802.5 MHz  
 N=1/8 for frequencies 802.5 to <1705 MHz  
 N=1/4 for frequencies 1.605 to <3.21 GHz  
 N=1/2 for frequencies 3.21 to <6.42 GHz  
 N=1 for frequencies 6.42 to <12.84 GHz  
 N=2 for frequencies 12.84 to <25.68 GHz  
 N=4 for frequencies 25.68 to 51 GHz

# Sweeping Capability

Sweeps can be performed with combined internal or external AM/FM/PM/pulse modulation running. With modulation enabled, the minimum switching speed increases to 2 ms.

Parameter	Nominal	Note
<b>Sweep parameters</b>	Frequency, power, phase, list	
<b>Sweep types</b>	Linear, logarithmic, random	
Switching Speed ( $t_{switch}$ ) <sup>1</sup> = $T_{delay} + T_{setup}$	500 $\mu$ s to 19998 s $\leq 10 \mu$ s (spec) $\leq 20$ ms	Standard Option UNZ Only when crossing Option xE1 power ranges including manual xE1 selection via SCPI command <sup>2</sup>
Time resolution	5 ns	
Timing delay ( $t_{delay}$ )	50 ns	Standard and UNZ
Settling time ( $t_{settling}$ )	3 $\mu$ s	Standard and UNZ
Timing accuracy per point	5 ns	Standard and UNZ
Sweep list length	2 to 10000	Per channel

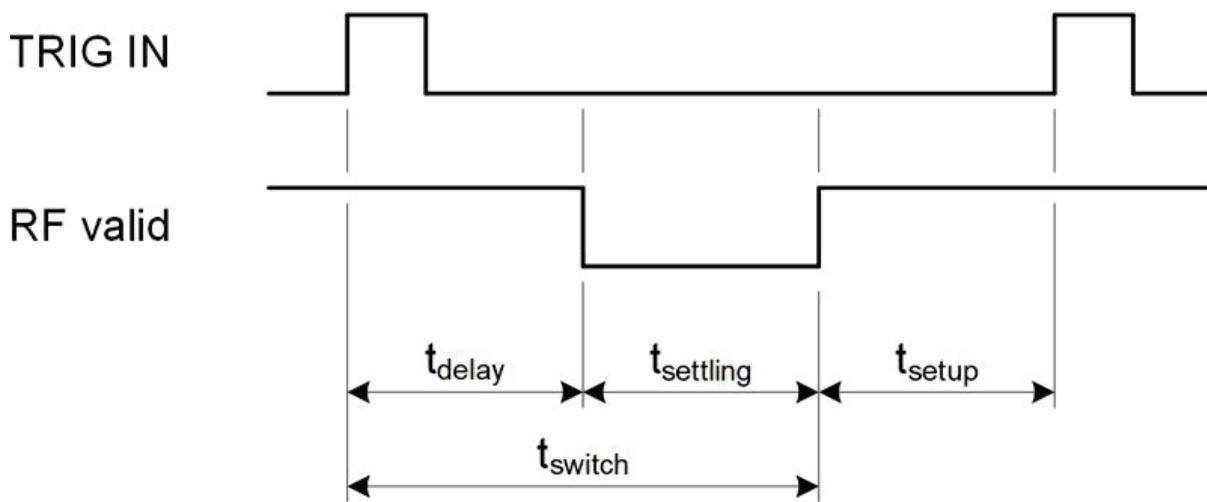

Figure 14. Timing diagram

# Trigger Input

Parameter	Nominal	Note
Trigger types	Continuous Single (point) Gated Gated direction	

<sup>1</sup> Switching speed is defined as the time it takes, after receipt of trigger, to change frequency or amplitude and settle to 0.1 ppm of its final value.

<sup>2</sup> With manual 1E1 selection, the user can move the fast dynamic range (down to 10  $\mu$ s with option UNZ) to a power range lower than -20 dBm, as long as attenuator power ranges are not being crossed during the signal change.

Trigger source	External Bus (LAN, USB)	
Trigger modes	Continuous free run Trigger and run Reset and run	
Trigger latency	5 ns	
Trigger uncertainty	10 ns	
External trigger delay	50 ns to 40 s	settable
External delay resolution	5 ns	
Trigger modulo	1 to 255	execute only on Nth trigger event
Trigger polarity	Rising, Falling	
External trigger input threshold	0.9 V	TTL compatible
External trigger input voltage range	-0.5V to +5.5V	TTL compatible
External trigger input hysteresis	60 mV	

## Multi-Purpose Output

Parameter	Nominal	Note
<b>Video Output (of internal pulse modulator)</b>		
Output	CMOS	
Period	30 ns to 50 s	
Pulse width	15 ns to 50 s	
RF delay	10 ns	
<b>Trigger Output. Synchronization Mode for Multiple Sources</b>		
Modes	Trigger on sweep start Trigger on each point Signal valid	

# Connectors

## Single-Channel AP5031A Front Panel (desktop enclosure)

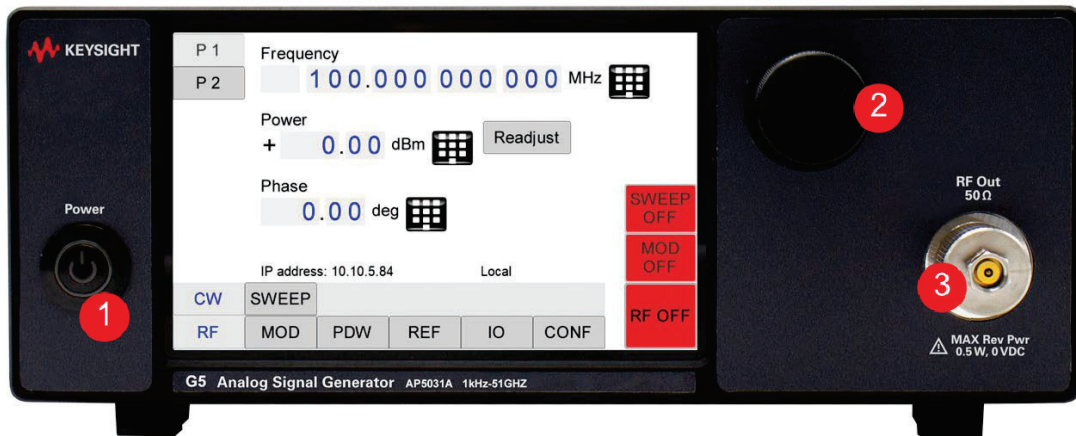

1. Power switch
2. Rotary knob
3. RF Outputs:
  - AP5031A-512: N female
  - AP5031A-520 or AP5031A-540: 2.92 mm male hand-tight
  - AP5031A-551: 1.85 mm male hand-tight

## Single-Channel AP5031A Rear Panel (desktop enclosure)

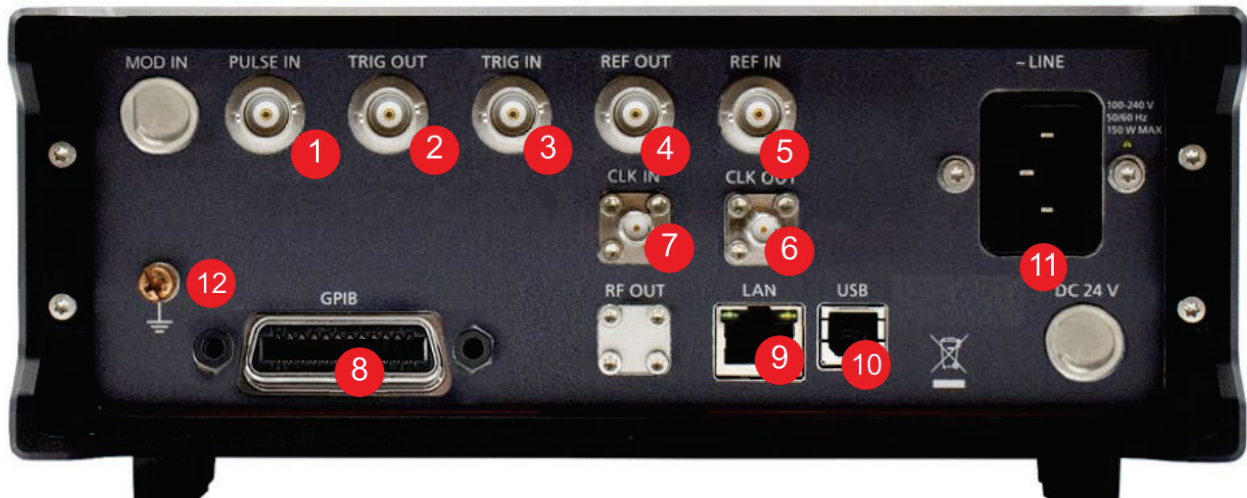

1. PULSE IN: Pulse modulation input: BNC female
2. Trigger output (TRIG OUT): BNC female
3. Trigger input (TRIG IN): BNC female
4. Reference output (REF OUT): BNC female
5. Reference input (REF IN): BNC female
6. High stability reference output (CLK OUT, 3 GHz): SMA female
7. High stability reference input (CLK IN, 3 GHz): SMA female
8. GPIB: IEEE-488.2, 1987 with listen and talk (option GPB)
9. LAN connection: RJ-45
10. USB 2.0
11. 100-240V AC power plug
12. Ground reference screw (earth) M4

## Multi-Channel AP5032A Front Panel (19" 2 HU)

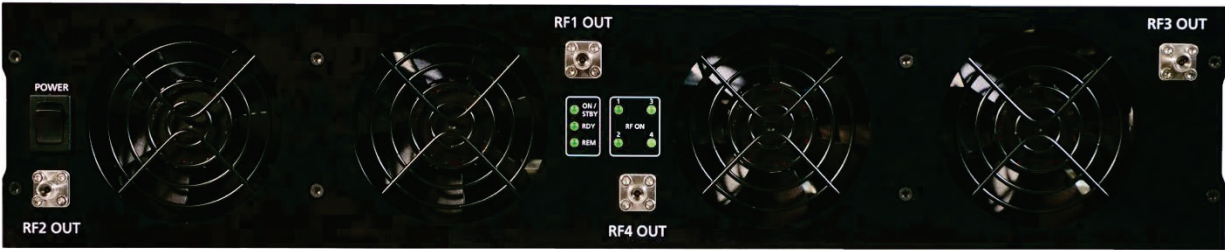

RF outputs:

- AP5032A-512 or AP5032A-520: SMA female
- AP5032A-540: 2.92 mm female
- AP5032A-551: 1.85 mm female

## Multi-Channel AP5032A Rear Panel (19" 2 HU)

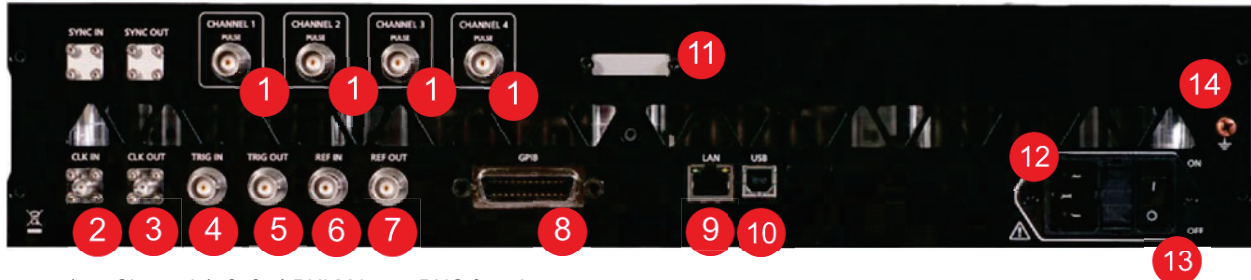

1. Channel 1, 2, 3, 4 PULM input: BNC female
2. High stability reference input (CLK IN, 3 GHz): SMA female
3. High stability reference output (CLK OUT, 3 GHz): SMA female
4. Trigger input (TRIG IN): BNC female
5. Trigger output (TRIG OUT): BNC female
6. Reference input (REF IN): BNC female
7. Reference output (REF OUT): BNC female
8. GPIB: IEEE-488.2, 1987 with listen and talk (option GPB)
9. LAN connection: RJ-45
10. USB 2.0
11. FUSE (3.15 A)
12. 100-240V AC power plug
13. Power switch
14. Ground reference screw (earth) M4

# Mechanical Specifications

## AP5031A Desktop Enclosure: Dimensions and Weight

Including connectors

W x L x H = 232 x 393 x 96.75 mm [9.1 x 15.5 x 3.8 in], ≤10 kg [22 lbs]

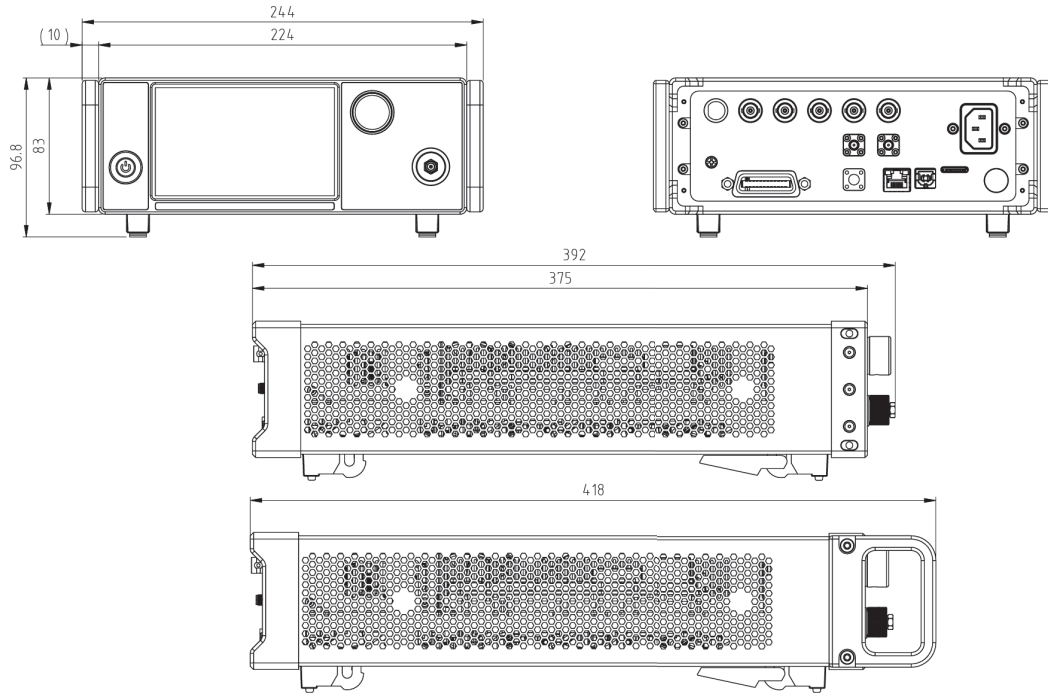

## AP5032A 19" 2 HU: Dimensions and Weight

Including connectors

W x L x H = 444 x 594 x 88 mm [17.5 x 23.4 x 3.5 in], 18 kg [39.7 lbs]

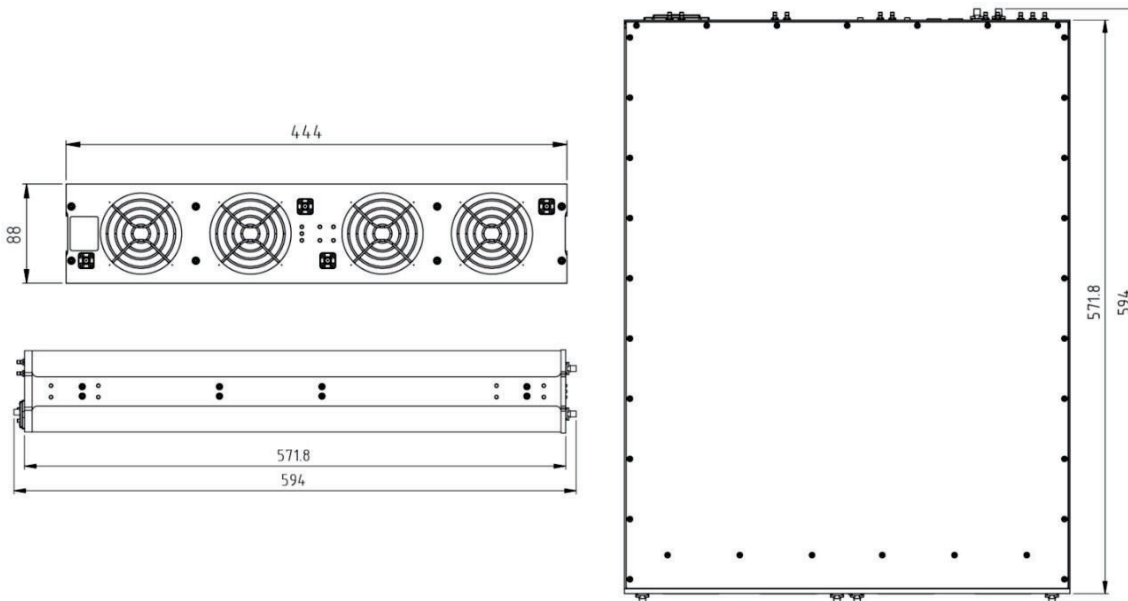

# General Characteristics

## Remote Programming Interfaces

- 10/100/1000 Mbit Ethernet interface
- USB 2.0
- GPIB (IEEE-488.2,1987) with listen and talk (Option GPB)
- Control Language SCPI Version 1999.0

**Power requirements:** 100 - 240 VAC, 50 or 60 Hz, AP5031A 100W max, AP5032A 200W max (80 W + 30 W per channel)

**Environmental:** Levels similar to MIL-PRF-28800F Class 3/4

**Operating ambient temperature range:** 0 to +45 °C

**Storage ambient temperature range:** -40 to +70 °C

**Relative humidity range:** 20 to 85 % (desktop models), 20 to 90 % (rack mount models)

**Operating and storage altitude** up to 15,000 ft/4600 m (AP5032A), up to 6560 ft/2000 m (AP5031A)

**Recommended calibration cycle:** 24 months



Safety / EMC comply with applicable Safety (IEC 61010-1:2010, IEC 61010-1:2010/AMD1:2016) and EMC (IEC 61326-1:2020) regulations and directives.

## Weight:

Multi-channel: 19" 2HU enclosure 18 kg [39.7 lbs]

Single-channel: Desktop enclosure ≤10 kg [22 lbs]

## Dimensions:

Multi-channel: 19" 2HU enclosure W x L x H = 444 x 594 x 88 mm [17.5 x 23.4 x 3.5 in]

Single-channel: Desktop enclosure W x L x H = 232 x 393 x 96.75 mm [9.1 x 15.5 x 3.8 in]

Keysight enables innovators to push the boundaries of engineering by quickly solving design, emulation, and test challenges to create the best product experiences. Start your innovation journey at [www.keysight.com](http://www.keysight.com).



This information is subject to change without notice. © Keysight Technologies, 2025 - 2026, Published in USA, February 9, 2026 3125-1262.EN