

Understanding DC-Coupled and DC-Blocked Power Sensors

Abstract

Understanding power meter and sensor key specifications is vital for selecting the right equipment for power measurements. An often overlooked area is the DC or AC coupling characteristic of the power sensor. Choosing the wrong type of sensor can result in measurement inaccuracy—or even worse, damage to the power sensor. This article compares the DC-coupled sensors to AC-coupled ones (also known as “DC-blocked” sensors). Several application examples are included to illustrate the key differences. The article concludes with choices of both DC-coupled and DC-blocked sensors from Keysight Technologies, Inc. to suit the user’s application requirements.

Introduction

Choosing the right power sensor can be daunting as there are many different types in the market today. In general, key considerations for power sensors are the frequency range, power range, and measurement capabilities (i.e. CW, average or peak measurements). An often overlooked area in the selection criteria is to consider if the power sensor is DC coupled or DC blocked (AC coupled). Choosing the wrong type of sensor can result in measurement inaccuracy and damage to the power sensor.

Definitions for “DC-Coupled” and “DC-Blocked”

A DC-coupled sensor enables operations down to DC as there is no blocking capacitor that prevents DC or low-frequency signal components from entering the sensing element for power measurements. On the other hand, in a DC blocked sensor, a capacitor is serially placed in front of the sensing element to filter out any DC bias voltage or low-frequency components. To design a DC-blocked sensor that measures down to very low frequencies, the capacitor needs to be very large, which then poses a design challenge in achieving good input match or voltage standing wave ratio (VSWR) performance. The larger the capacitor, the greater the discontinuity would be in the 50-ohm characteristic impedance due to the transition from a tiny 50-ohm coaxial transmission line to a large capacitor structure.

Application Differences Between DC-Coupled and DC-Blocked Sensors

Compared to the DC-coupled sensor, a DC-blocked sensor typically has a wider application coverage since it is able to prevent any DC bias or leakage current from entering the sensing element (typical sensing elements are thermocouples and diode detectors). In some applications, the DC bias path is shared with the RF path, thus some amount of DC current will appear in the RF path and present an offset to the RF power measurement. When measuring RF power in the RF path, the DC current will feed through to the sensing element and affect the measurement accuracy.

Let's take a thermocouple sensor as an example. A thermocouple sensor is a heat-based sensor whereby the presence of RF energy heats up the thermocouple junction and generates a voltage level that is proportional to the input RF power. The voltage is then measured and related to a certain RF power level through calibration. However, the presence of a DC offset voltage on the RF input will also heat up the junction and result in erroneous measurement if all that's expected out of the measurement is the RF component. The following application example illustrates the manufacturing test setup of a Wi-Fi amplifier, where DC power is provided to the Wi-Fi amplifier through the antenna cable. If a DC-coupled sensor were used to measure power in the RF path, significant measurement inaccuracy will occur since the sensing element is not only detecting the RF power, but also the DC bias current.

Figure 1(a) and 1(b) illustrate alternative solutions to this problem. You can place either an external DC blocking capacitor module in front of the DC-coupled power sensor (Figure 1(a)) or a bias tee in front of the Wi-Fi amplifier (Figure 1(b)). The drawback of such setup is that there will be inherent measurement inaccuracy due to mismatch and losses incurred by the external DC blocking capacitor and bias tee. Measurement at the DC-coupled sensor no longer represents input RF power to the Wi-Fi amplifier.

Likewise, a DC-coupled sensor is also unsuitable for the calibration of network analyzers with a bias tee configuration. The bias tee enables application of a DC bias to the network analyzer's ports through BNC connectors at the instrument rear panel. In such a setup, the DC-coupled power sensor cannot perform accurate measurements as the RF output power from the network analyzer contains a DC offset level.

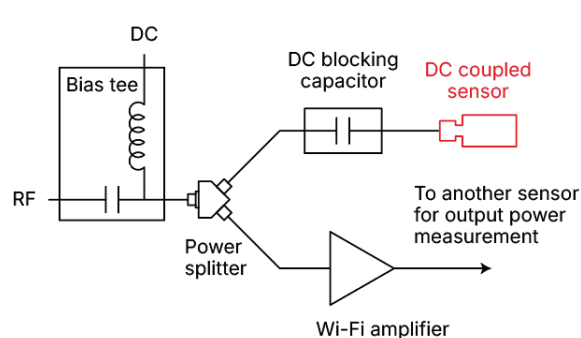

Figure 1(a). An external DC blocking capacitor is required to prevent the DC component from entering the DC-coupled sensor.

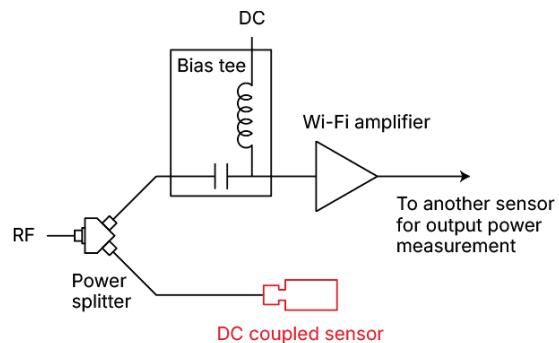

Figure 1(b). A bias tee has to be connected after the power splitter so that the DC component is blocked from entering the DC-coupled sensor.

Conversely, with a DC-blocked sensor, you won't have to face the problems you would with a DC-coupled sensor. Figure 2 shows how, with a DC-blocked sensor, there is no need for an external DC blocking capacitor in front of the power sensor, or a bias tee in front of the Wi-Fi amplifier. As such, the power splitter provides a matched tracking of its two outputs which ensures that the measured power is equivalent to the input power to the Wi-Fi amplifier.

Another difference between a DC-coupled sensor and a DC-blocked sensor is the maximum handling voltage. The maximum DC voltage handling capability of a DC-coupled sensor varies from 3 V to 5 V whereas a typical DC-blocked sensor would be able to withstand voltages up to 20 V. A DC-coupled sensor is easily damaged due to sensor overpowering. Through a simple voltage-power relation calculation, an RF input power of more than +23 dBm can potentially burn a DC-coupled sensor.

However, a DC-coupled sensor is not without benefits. Generally, DC-coupled sensors have a slightly better VSWR performance when compared to DC-blocked sensors since there is no blocking capacitor at the front end. DC-coupled sensors can also be used in applications that require operations at very low frequencies, even down to DC levels. This characteristic makes it an ideal choice for metrology applications where sensor calibration can be done via direct comparison methods, i.e., DC voltage from the sensor can be measured directly using a voltmeter.

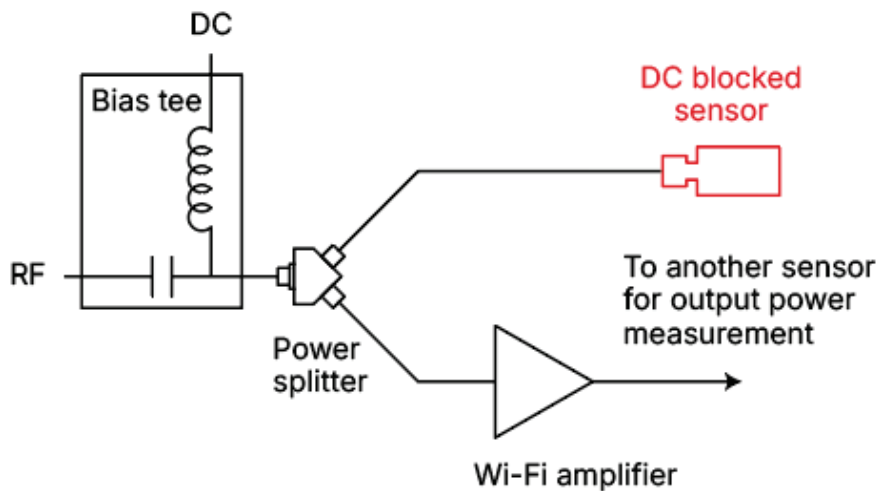

Figure 2. A DC-blocked sensor is a more appropriate equipment to measure the input power of the amplifier.

Design Challenges in DC-Blocked Sensors

Now that you know why DC-blocked sensors are preferable in performing more accurate RF power measurements, you may be wondering “Why aren’t all sensors designed that way?” Designing a DC-blocked sensor is no easy feat as the sensor needs to cover a wide frequency range—even high frequencies up to 70 GHz—while maintaining good VSWR and calibration factor performance. Good VSWR is vital for the overall sensor performance as VSWR is a key characteristic that impacts measurement uncertainty. Calibration factors help ensure good power-to-voltage conversion efficiency to maximize usable dynamic range and optimize measurement noise performance.

Innovative design and manufacturing process are keys to achieving superior VSWR and calibration factor performance, whilst maintaining manufacturability. Innovative power sensor designs include the meticulous design of the outer conductor structure to compensate for capacitance losses at high frequencies, in order to maintain good VSWR and frequency flatness. To optimize VSWR and calibration factor performance, the design of the capacitor has to be small enough to be buried into the tiny 1.85-mm connector center pin. Due to the level of complication and delicate structure involved, each step of the manufacturing processes has to be handled with great care and precision to ensure that the DC-blocked power sensor is able to perform excellently, as expected at high frequencies.

Conclusion



Now that you know why DC-blocked sensors are preferable in performing more accurate RF power measurements, you may be wondering “Why aren’t all sensors designed that way?” Designing a DC-blocked sensor is no easy feat as the sensor needs to cover a wide frequency range—even high frequencies up to 70 GHz—while maintaining good VSWR and calibration factor performance. Good VSWR is vital for the overall sensor performance as VSWR is a key characteristic that impacts measurement uncertainty. Calibration factors help ensure good power-to-voltage conversion efficiency to maximize usable dynamic range and optimize measurement noise performance.

Innovative design and manufacturing process are keys to achieving superior VSWR and calibration factor performance, whilst maintaining manufacturability. Innovative power sensor designs include the meticulous design of the outer conductor structure to compensate for capacitance losses at high frequencies, in order to maintain good VSWR and frequency flatness. To optimize VSWR and calibration factor performance, the design of the capacitor has to be small enough to be buried into the tiny 1.85-mm connector center pin. Due to the level of complication and delicate structure involved, each step of the manufacturing processes has to be handled with great care and precision to ensure that the DC-blocked power sensor is able to perform excellently, as expected at high frequencies.

Related Keysight Literature

Publication Title	Pub Number
Keysight N8480 Series Thermocouple Power Sensors Data Sheet	5989-9333EN
Keysight Power Meters and Power Sensors Brochure	5989-6240EN

References

1. Sook Hua Wong, "Understanding DC-coupled and DC-blocked power sensors and how your choice of sensor would impact measurement accuracy,"—New Electronics, 6/10/2010.
Retrieved from www.newelectronics.co.uk/

Keysight enables innovators to push the boundaries of engineering by quickly solving design, emulation, and test challenges to create the best product experiences. Start your innovation journey at www.keysight.com.



This information is subject to change without notice. © Keysight Technologies, 2017 – 2026, Published in USA, April 17, 2026, 5990-6745EN